

RSCDS-BB Ball 2025



The RSCDS Breton Branch (RSCDS-BB) is organising its third international ball in Josselin (Morbihan) from **Friday 12th until Sunday 14th September 2025**.

- Details at <https://rscds-bb.fr/index.php/en/ball-2025/ball-organisation-2025>
- Registration form at <https://rscds-bb.fr/en/ball-2025/ball-2025-registration>
- POC: info@rscds-bb.fr

1 GRANVILLE MARKET J32 · 3/4L

Elinor M Vandegrift: A Second Book of Graded Scottish Country Dances · Crib: E-cribs · Diagram: Keith Rose's Diagrams

- 1- 1c+2c RHA, LHA
- 9- 1c cross RH | cast (2c up) ; ½ Fig8 up to face 1cnr
- 17- 1c turn 1cnr RH | pass Rsh ; turn 2cnr RH | pass Rsh to (2,1,3)
- 25- Circle6 and back

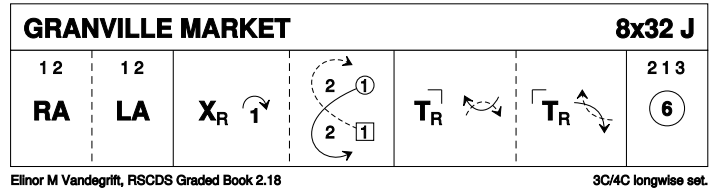

2 THE KISSING BRIDGE R32 · 3/4L

Romaine Butterfield: RSCDS XLVII 9 · Crib: E-cribs · Diagram: Keith Rose's Diagrams

- 1- 1c cast behind own lines and cast back
- 9- 1c cross down into Mirror Reels3 on opposite sides (1x,2,3)
- 17- 1c lead down, cross (M below W, who passes under M's arm) ; and up, 2c steps in for
- 25- 1c+2c Pousette

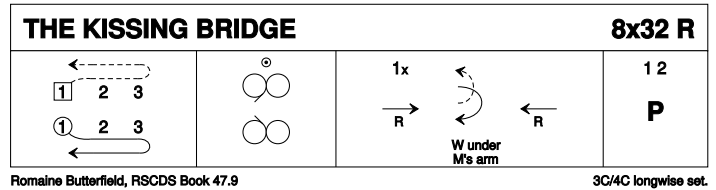

3 BUTTERSCOTCH AND HONEY S32 · 4/4L

Jean Attwood: Braes o' Lochaber and Three More Scottish Country Dances · Crib: E-cribs · Diagram: Keith Rose's Diagrams

- 1- 1c set, ½ RH turn to promhold facing down ; ½ Rsh Reel3 across with 2c, 2c finish in 1plx
- 9- ½ Lsh Reel3 across with 3c, 3c finish in 2plx ; repeat Rsh with 4c to (2x,3x,4x, 1x)
- 17- 1c leading, all cast up outside sidelines to the top, cross Lsh to P and dance down on own sidelines (2,3,4,1)
- 25- All set and turn partners BH ; 2c+3c & 4c+1c Circle4 L.

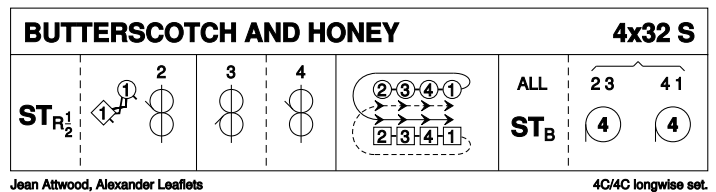

4 THE WILD GEESE J32 · 3/4L

RSCDS XXIV 3 · Crib: E-cribs · Diagram: Keith Rose's Diagrams

- 1- 1c+3c set advancing to midline with P on R | BiL ; 1c turn $\frac{3}{4}$ RH and cast off to 3pl **while**{4} 3c turn $\frac{3}{4}$ RH and lead to 1pl (3,2,1)
- 9- Repeat [1-8] from new positions (1,2,3)
- 17- 1c lead down the middle (2c up on [19-20]) ; and up to (2,1,3)
- 25- 2c+1c R&L

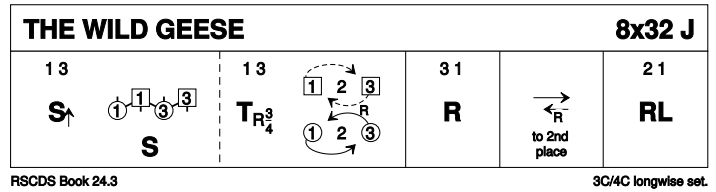

5 DOUBLE TROUBLE TRIANGLES R48 · 4/4L

Judith Kowalczyk: RSCDS 50 8 · Crib: E-cribs · Diagram: Keith Rose's Diagrams

- 1- 1M+4W set | A&R | set **while**{8} 1W+4M stand | set ; advance | set (bar 5-8 RHJ with P)
- 9- 1c+2M & 4c+3W RHA (2M+3W finish in end places) | 1c+2W & 4c+3M LHA (2c+3c now in end places, 1c+4c finish outside set on opp. side, 1W & 4M facing out)
- 17- 1W & 4M, each followed by P, cclw cast 2 places and finish on midline BtoB with P, 4c above 1c, M facing up, W down ; 2c+4M & 1W+3c circle3 **while**{4} middles turn LH $\frac{1}{2}$ | clap and turn RH $\frac{1}{2}$
- 25- 1W+3c & 4M+2c set as in DTr **while**{2} middles $\frac{1}{2}$ turn BH | 1W+4W & 1M+4M change places as in DTr **while** 2c+3c set ; repeat [25-28] from exchanged places, but finish 1c & 4c (with W on L) in middle facing up NHJ
- 33- 1c followed by 4c lead up and cast off, 1c to 3plx, 4c to 2plx ; 1c+4c $\frac{1}{2}$ Fig8 round end cpl (2,4,1,3)
- 41- All $\frac{1}{2}$ turn P RH, finish in the middle, facing P RHJ | set ; pass RSh to own side | All set (2,4,1,3)

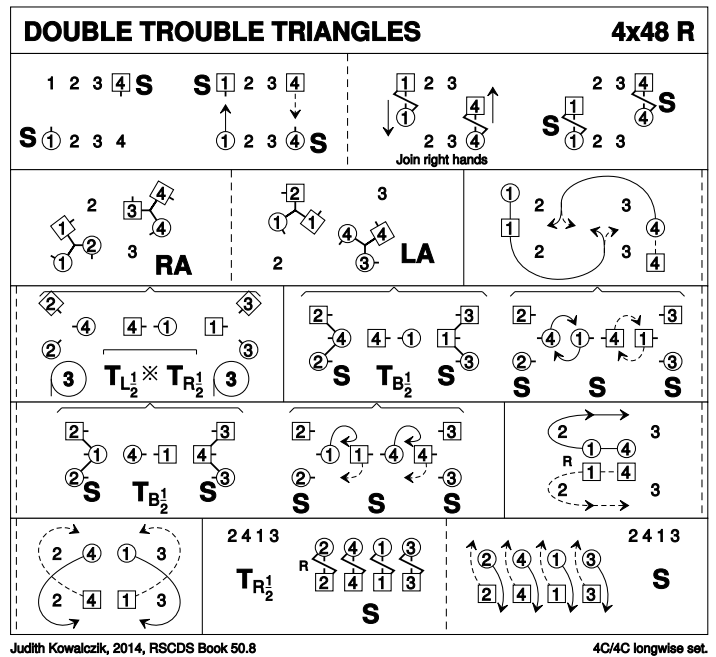

6 KARIN'S STRATHSPEY S32 · 3/4L

Derek Haynes: A Third Book of Graded Scottish Country Dances · Crib: E-cribs · Diagram: Keith Rose's Diagrams

- 1- 1c+2c the Knot
- 9- 1c & 1cnrs set, 1c advancing to end BtoB | 1c turn corner BH ; open into circle4 L, ending with 1cnrs in places and 1W+2c & 1M+3c forming lines across
- 17- 1c repeat with 2cnrs, to finish between corners
- 25- Lsh Reels3{6} on opposite sides with cnrs | 1c cross to own side

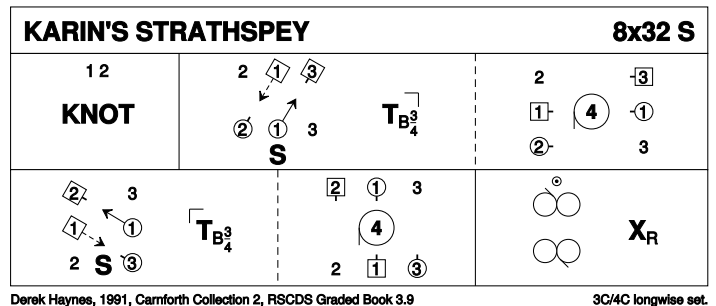

7 FAREWELL TO BALFOUR ROAD J32 · 5/5L

Andrew Buxton: RSCDS LII 7 · Crib: E-cribs · Diagram: Keith Rose's Diagrams

- 1- 1c+2c Circle4 and back
- 9- 1c+2c Set&Link ; 1c+3c Set&Link
- 17- [2c in 1pl start dancing as 1c]
1c+4c+5c Mirror Reels3 on sides, 1c in and down
- 25- 1c in 3pl set | cross down RH to 4plx (4c up) ; 1c in 4pl set | cross down LH to 5pl (5c up)

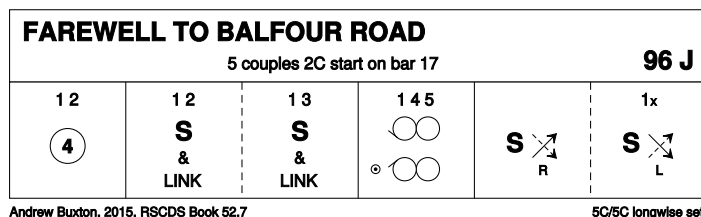

Deviser's Note : A new top couple begins every sixteen bars until the original 1st couple reach the top of the set again.

8 TOAST TO THE MOUSIES R32 · 3/4L

Sara Gratiot: RSCDS LIII 13 · Crib: E-cribs · Diagram: Keith Rose's Diagrams

- 1- 1c long cast to 2pl (2c up) ; dance between 3c and cast up (2,1,3)
- 9- 2c+1W & 1M+3c RHA ; 2c+1M & 1W+3c LHA, finish 2c in 1pl facing 3c in 3pl, both NHJ, and 1c BtoB in middle, M facing up, W down
- 17- All set | 2c+3c, making arches, dance to meet as 1c dance under, finish 1c (in 1pl/3pl) facing P on midline and 2c+3c BtoB in middle, NHJ ; All set | 2c+3c making arches dance to ends, and cast into the reel **while{2}** 1c dance under arch passing P Lsh and finish between end cpl, facing 1cnr
- 25- 2c+1W & 1M+3c Lsh Reels3{6} across (2c+3c with loops) (to 2,1,3) | All set

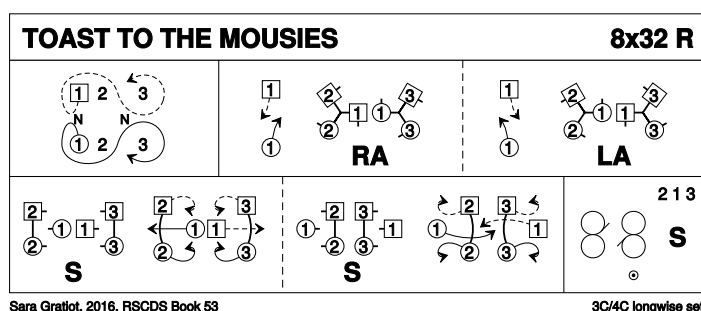

Note: after 2nd time through 1c may repeat [1-4] to get to 4pl.

9 LOST IN THE DREAMING SPIRES S32 · 3/4L

Niall Bootland: The Oxford Collection · Crib: E-cribs · Diagram: Keith Rose's Diagrams

- 1- 1c cross RH | cast off (2c up) ; ½ Fig8 to L RSh round 4cnrs (2,1,3)
- 9- 3C *Espagnole*: 2M+1M & 1W+3W lead RHJ to opp sides and cross **while{2}** 2W & 3M chase 1 place cclw (to M side: 2W,3W,1W, W side: 1M,2M,3M) | repeat same pattern from new positions (to M side: 1M,3M,2M, W side: 3W,2W,1W) ; 3W+1M "top couple" & 1W+2M "bottom couple" turn LH **while{4}** 2W+3M "middle couple" turn RH (M side: 1M,3M,2M, W side: 3W,2W,1W)
- 17- 3C Bourrel (2,1,3)
- 25- Circle6 and back (2,1,3)

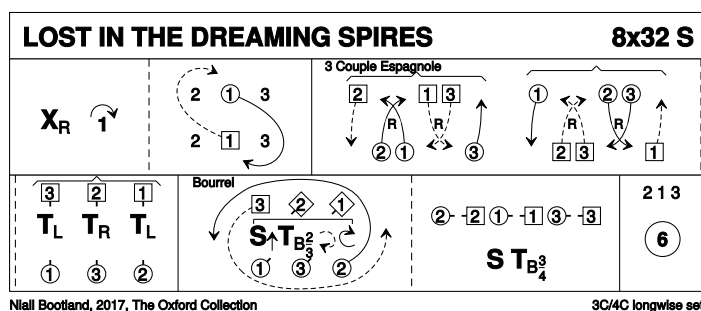

>----- BREAK -----<

10 LINKS WITH ST PETERSBURG J32 · 3/4L

Malcolm Brown: RSCDS XLVI 10 · Crib: E-cribs · Diagram: Keith Rose's Diagrams

- 1- 1c+2c S&Link, finish 2c facing 1c NHJ ; S&Link to (2x,1x,3)
- 9- 1c, 2c following, dance down {3}, change sides with NHJ, W passing above M and under his arm, 2c+1c dance up to (2,1,3), 2c facing out
- 17- 2c turn 1c EH on sides ; 1c turn 3c EH, 1c finish BtoB facing 1cnr
- 25- SetH&G , petronella to (2,1,3)

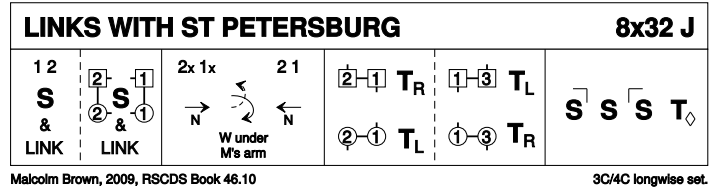

11 THE BON VIVEUR M64 · 4S

Ian Brockbank: RSCDS LII 11 · Crib: E-cribs · Diagram: Keith Rose's Diagrams

- 1- Circle8 and back
- 9- 1c+3c Men's Chain
- 17-28 12 bars of Schiehallion reel (4,1,2,3)
- 29-32 All Birl or Turn P RH (4,1,2,3)

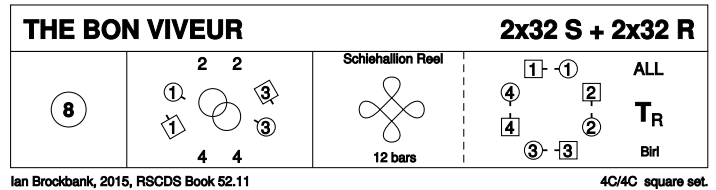

12 MRS STEWART'S JIG J32 · 3/4L

Frans Ligtmans: RSCDS XXXV 1 · Crib: E-cribs · Diagram: Keith Rose's Diagrams

- 1- 1c set | 1W casts, 1M following, round 3W, 1W dances up round 3M and 1M dances up the middle, 1c face 3c (2c up on 7-8) (2,1x,3)
- 9- 2c+1c+3c G-Chain (2c cross), 2M+1M finish facing out
- 17- 2c+1c L-Chain
- 25- 2c+1c+3c A&R ; 1c turn RH 1½ to (2,1,3)

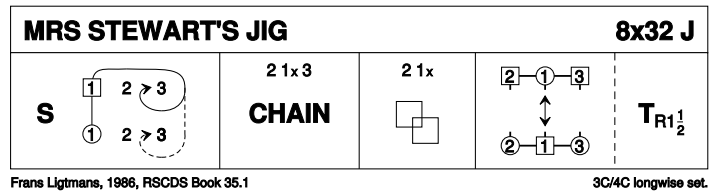

13 RED HOUSE R40 · 2/4L

Playford: RSCDS VII 2 · Crib: E-cribs · Diagram: Keith Rose's Diagrams

- 1- 1c set and cast off one ; set and cast back
- 9- 1M cast off (1W follows) behind 2M, between 2c, behind 2W and cross to finish below 2M/2W
- 17- 1W cast up (1M follows) behind 2W, between 2c, behind 2M and cross to finish 1c in own places
- 25- 1c+2M Reel3 on M sideline (1M & 2M begin Lsh, 1W entering below them ; 1M+2M end in exchanged places, 1W in own place
- 33- 1c+2W Reel3 on W sideline (1W & 2W begin Rsh, 1M entering below them, finish (2,1)

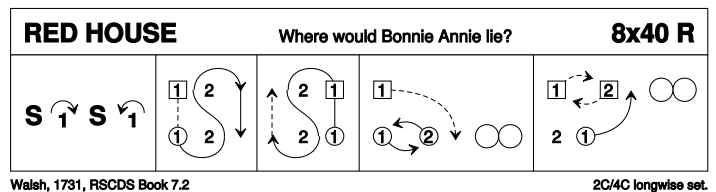

14 THE CRAMOND WEDDING S32 · 3/3L

Roy Goldring: 25 Years On - New Kilpatrick · Crib: E-cribs · Diagram: Keith Rose's Diagrams

- 1- 1c cross down (no hands) to 2plx facing out and R **while{2}** 2c dance up and face in | Reels3{6} on the sides (Rsh to 1cnr), 1c finish BtB facing 1cnr
- 9- 1c set to and turn 1cnr BH $\frac{3}{4}$ to finish between end couples, retaining NH with 1cnr ; All cross up/dn, 3M & 2W dancing under the arch they meet | 1c turn 1cnr person BH $\frac{3}{4}$ to finish (3,1x,2)
- 17- Teapots R (1M up, 1W down) to sidelines ; 1c $\frac{1}{2}$ Fig8 L (1W up, 1M down) to 2pl. On [24] 2c+3c step in for
- 25- 3c+1c+2c Allemande. on [31-32] 1c casts to 3pl and 3c dance to 2pl (2,3,1)

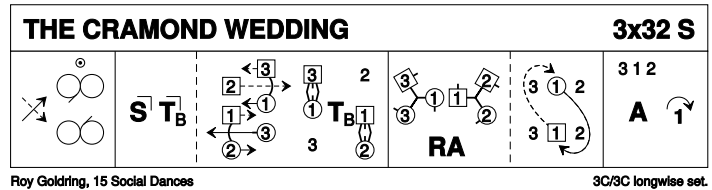

15 RED GHILLIES R40 · 4/4L

Ann Skipper & Neil Stewart McLeod: If The Ghillie Fits · Crib: E-cribs · Diagram: Keith Rose's Diagrams

- 1- 1c cross between 2c, cast behind 3c ; cross down and cast up round 4c
- 9- 1c cross up between 3c and cast behind 2c to top ; turn RH $1\frac{1}{2}$ to 1pl
- 17- 1c+2c $\frac{1}{2}$ R&L ; 1c+3c $\frac{1}{2}$ R&L
- 25- 1c+4c $\frac{1}{2}$ R&L ; All turn RH (2x,3x,4x,1x)
- 33- All set | All "La Baratte" [turn P RH $\frac{1}{2}$ to full arms' length | change back sideways, W passing in front with her back to M, changing hands overhead to LH | turn LH $\frac{1}{2}$ to own side] (2,3,4,1)

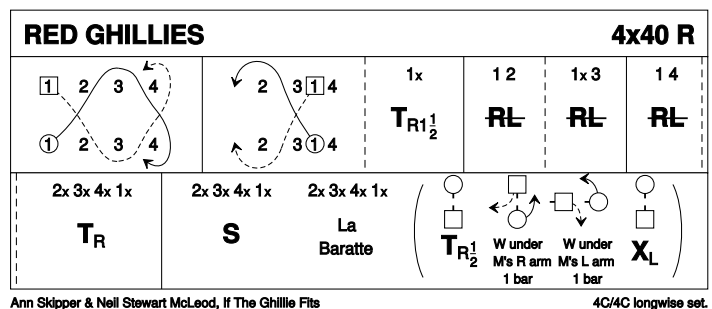

16 QUARRIES' JIG J32 · 3/4L

Kent W Smith: RSCDS XXXVI 3 · Crib: E-cribs · Diagram: Keith Rose's Diagrams

- 1- 1c set | cast (2c up) ; $\frac{1}{2}$ Fig8 Lsh round 1cnr (2,1x,3)
- 9- 1M+2c and 1W+3c Lsh Reels3 across, at end 1c LH turn to face 1cnrs
- 17- 1c+1cnrs change places RH **while{2}** 2cnrs set | centre dancers change places LH **while{2}** the others chase clw one position ; repeat from new positions
- 25- Repeat from new positions, but to finish 1c turn LH to 2plx ; 2c+1c+3c set | 1c cross RH.

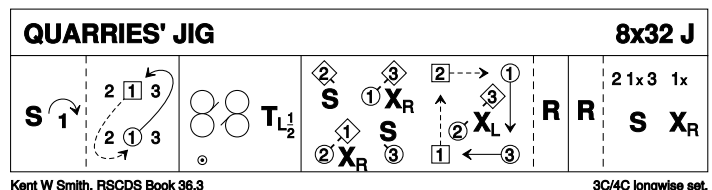

17 THE FLOWER OF GLASGOW S32 · 3/3L

Ruth Taylor: RSCDS XLVI 9 · Crib: E-cribs · Diagram: Keith Rose's Diagrams

- 1- 1W, 1M following, cast off 2, cross below 3c ; 1W cast up and 1M dance up the middle and 2c dance up (to 2,1x,3) | All set adv into promhold, 1c facing down, 2c & 3c up
- 9- Circulating Allemande: all dance as in a normal 3c allemande, only 1c starts down, finish (3,1x,2)
- 17- 1c $\frac{1}{2}$ Fig8 L (W up M down) ; all turn P BH (3,1,2)
- 25- 1c+2c Poussette (3,1,2)

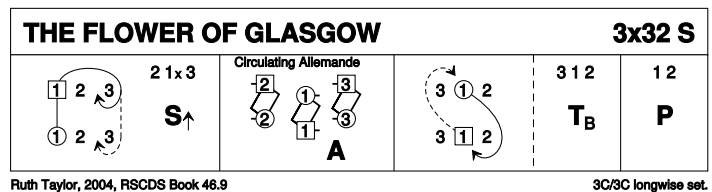

18 SHIFTIN' BOBBINS R32 · 3/4L

Roy Clowes: *Thirty Popular Dances, Volume Two* · Crib: *E-cribs* · Diagram: *Keith Rose's Diagrams*

- 1- 1c cross down RH (2c up) to 2plx in DTr position with corners | set as DTr ; cast up, meet and dance down to 2pl in middle
- 9- 2M+1W+3M RHA, **while{4}**
2W+1M+3W LHA ; 1c followed by 2c+3c dance down the middle
- 17- 3c+2c+1c dance up the middle, 3c casting to 3pl, flowing into ; 1W+2M+3M LHA, **while{4}**
1M+2W+3W RHA
- 25- 1c dance to top, cast off one ; ½ Fig8 up round 2c.

